



SWH-3114SFP

12 Ports 10/100/1000BASE-T Managed Ethernet Switch with 2 SFP slots Uplink

KEY FEATURES

- Comply with IEEE 802.3 10BASE-T, 802.3u 100Base-TX, 802.3ab 1000Base-T, & 802.3z 1000Base-X standards
- Comply with Metro Ethernet MEF9 UNI standard
- Twelve 10/100/1000Base-T ports and 2 SFP slots
- Store and Forward Switching Mechanism
- Auto-Cross over for MDI/MDI-X in TP port
- Auto-Negotiation in TP port
- Support Power ,Console , Fiber 1 , Fiber 2, Link/Act , Speed LED
- Support SNMP, Web, Telnet and Console management
- Comply with IEEE 802.1p Priority
- Comply with IEEE 802.1q Tag VLAN
- Comply with IEEE 802.1w Rapid Reconfiguration of Spanning Tree
- Support IEEE 802.3ad Link Aggregation up to 6 trunks and 12 ports in a trunk
- Support jumbo frame on all ports up to 9k size
- Support QoS Classification based on IEEE802.1p and DSCP
- Support Double Tag VLAN (Q-in-Q)
- Support Rate Limit Control
- Support SNTP Time Server
- Support IGMP Snooping v1, v2 and v3 *
- Support DHCP client and provision server
- Support FTP, TFTP server and client firmware upgrade
- Support SNMP v1, v2c and v3 * network management
- Support private, RFC-1213, RMON
- Support Power Down Trap Management
- Support Radius Authentication
- Book size form factor for convenience of FTTX installation



Mark “*” means coming soon.

DESCRIPTIONS

SWH-3114SFP Switch from Connection Technology Systems adopts the emerging CTS technology and able to expand a copper based network from 550m up to 80km through optical fibers. It is going to provide robust and versatile features to fulfill the FTTX demand like Gigabit bandwidth, QoS, Q-in-Q VLAN stacking, Rate limit, SNMP and Web Management. In addition, to achieve the max compatibility with other Metro-Ethernet equipment, SWH-3114SFP is designed to fully comply with MEF9 UNI test standard.

SWH-3114SFP is fully compliant with IEEE802.3, 802.3u, 802.3ab, and 802.3z standards. The installation & operation procedures of SWH-3114SFP are simple & straightforward. Diagnostic LEDs located in the front panel indicate the real time operating status.

APPLICATION

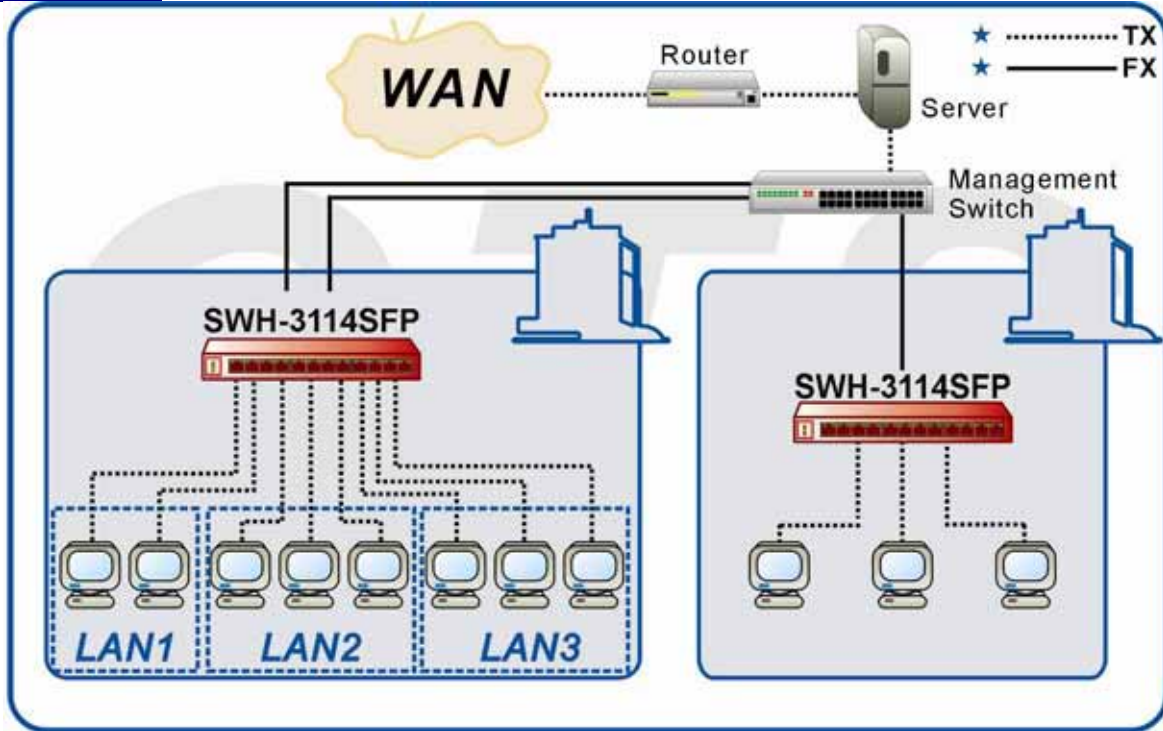

SPECIFICATIONS

Standard

IEEE 802.3 10Base-T
IEEE 802.3u 100Base-TX
IEEE 802.3ab 1000Base-T
IEEE 802.3z 1000Base-X
IEEE 802.1w Rapid Spanning Tree
IEEE 802.1p Priority
IEEE 802.1q Tag VLAN
IEEE 802.3ad Link Aggregation

Interface

10/100/1000Mbps RJ-45 port x 12
1000Mbps SFP slots x 2

LED

Power , Console , Fiber 1 , Fiber 2 ,
Link/Act , Speed

Redundancy

TP/FX all support

Product Spec:

Mac address table: 8K
Memory buffer: 340K
VLANs: Support up to 64 VLAN
Groups
Priority Queues: 4 Queues

Forward / Filter Rate

10M: 14,880/14,880pps
100M: 148,800/148,800pps
1000M: 1,488,000/1,488,000pps

Power

External Power adapter:
Input AC 120V-240V
Output DC 12V
Power Consumption: 15W

Typical Operation & Storage Temperature

Operation: 0° ~ 50
Storage Temperature: -20° ~ 60
Humidity: 5% ~ 90% non-condensing

Dimension & Weight

Size: 240 x 155 x 34 mm (WxDxH)
Shipping Weight: 1.75KG

Emission/Safety

FCC Class A, CE
* For further reports, please contact
us for update.

ORDER INFORMATION

SWH-3114SFP